

Data Sheet LB-800A-51

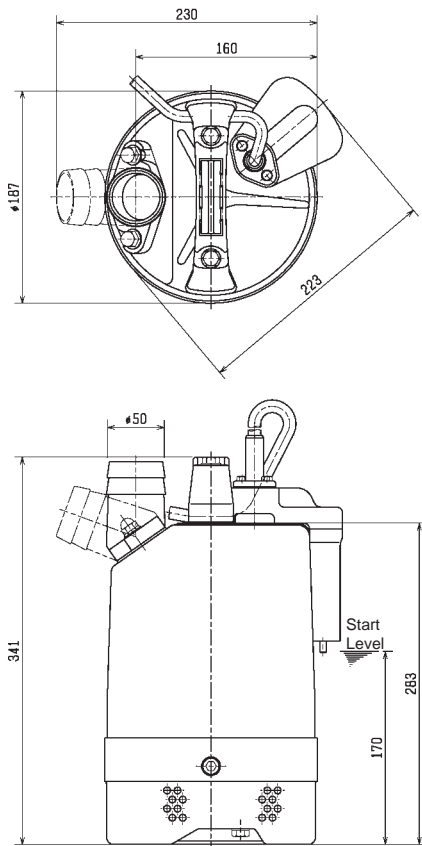

Dimensions in mm

LB-800A-51

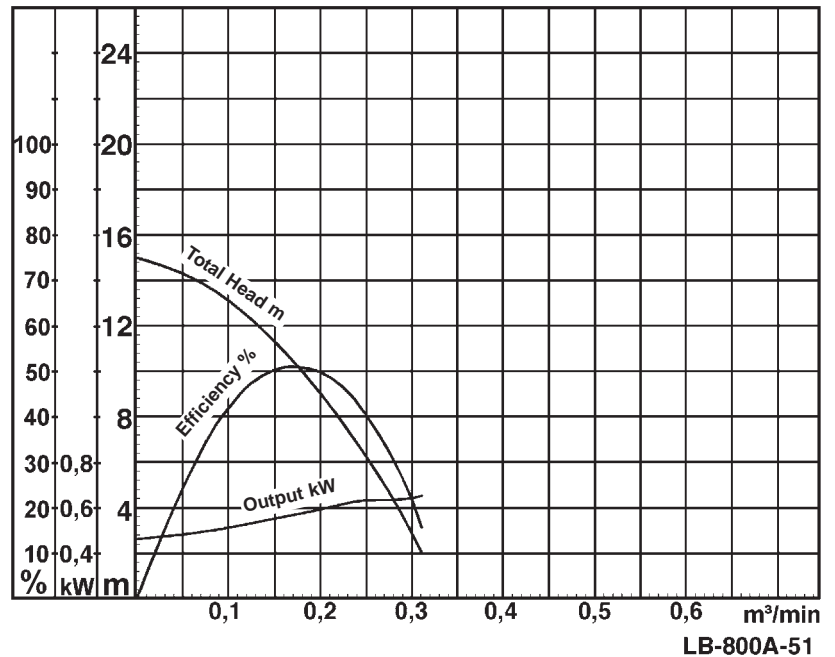

LB-800A-51

Classification

Automatic electric submersible pump with water sensor (electrodes)
 Protection class IP68
 Depth of submersion max. 20m
 Semi-vortex impeller
 Max. solid handling 6mm
 Suitable for rain water, font water, ground water, sand carrying water

Electric Motor

Dry-type submersible induction motor
 Insulation class E, 2 poles, 2730 r.p.m.
 Capacitor start
 Voltage: 230V, 50Hz, 1-phase
 Power input: 1,13kW
 Power output: 0,75kW
 Nominal current: 5,0A
 Start current: 12,3A

Electric cable

10m H07RN-F 3Cx1mm²

Motor Protection

Circle thermal protector
 (snap-action bi-metal device)

Shaft Seal

Double mechanical seal in oil bath
 Primary Seal:
 silicon carbide on silicon carbide
 Secondary Seal:
 carbon on ceramic

Bearings

Shielded ball bearings, maintenance-free

Materials

Impeller:	Urethane rubber
Casing:	BR +Natural rubber
Suction Plate:	Steel plate +Urethane rubber
Motor frame:	Aluminium alloy casting
Shaft:	SUS403 (EN-X6Cr13)

Discharge Connection

2" (50mm) BS-Coupling (threaded flange)

Weight

13,8 kg (dry weight of the pump without cable)

Dimensional Drawing LB-800A-51

Dimensions in mm

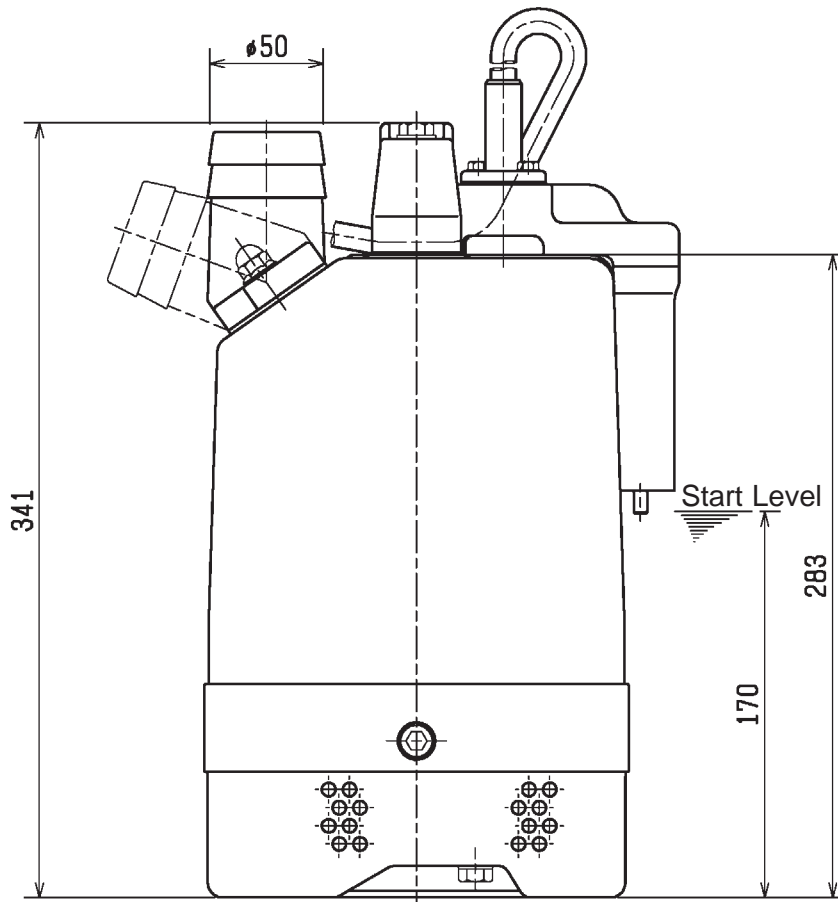
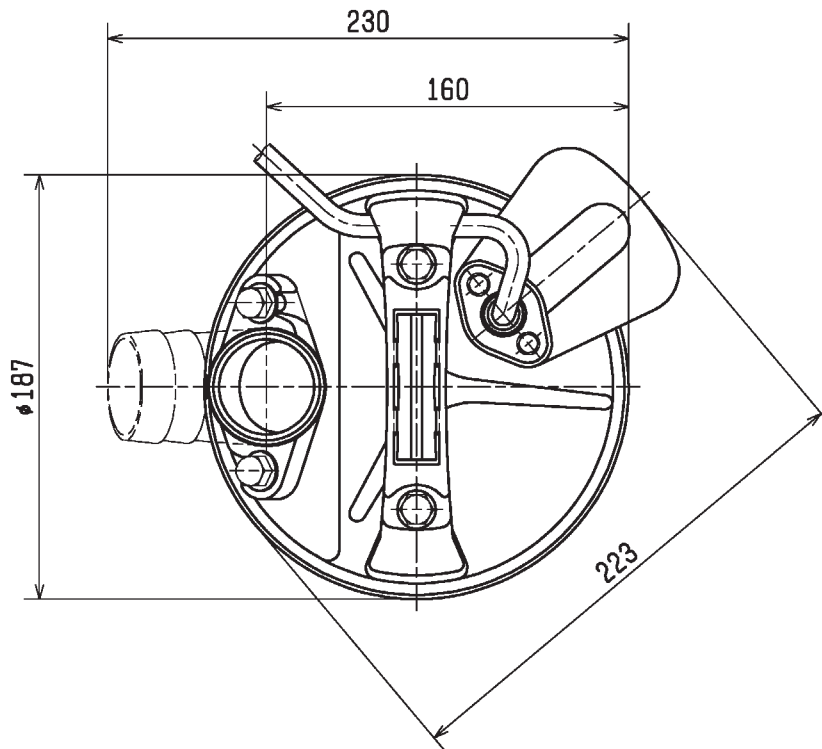

LB-800A-51

Sectional Drawing LB-800A-51

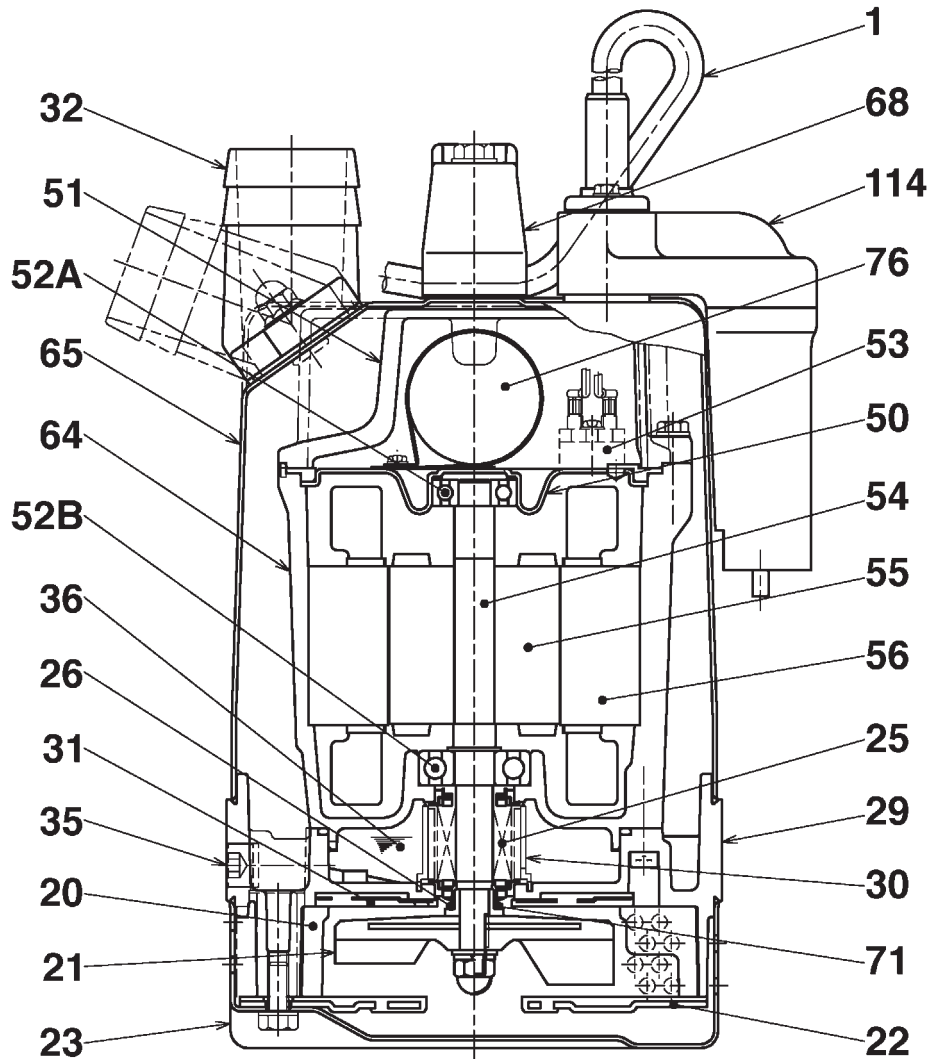

LB-800A-51

No.	Description	Qty.	Remarks	No.	Description	Qty.	Remarks
1	Cable	1	H07RN-F	51	Motor Head Cover	1	Aluminium Die Casting
20	Pump Casing	1	BR + Natural Rubber	52A	Upper Bearing	1	6201ZZC3
21	Impeller	1	Urethane Rubber	52B	Lower Bearing	1	6302ZZC3
22	Suction Cover	1	Steel Plate + Urethane Rubber	53	Motor Protector	1	
23	Strainer Stand	1	Steel Plate	54	Shaft	1	SUS403 (EN-X6Cr13)
25	Mechanical Seal	1	W-14VL	55	Rotor	1	
26	V-Seal	1	NBR	56	Stator	1	
29	Oil Casing	1	Aluminium Die Casting	64	Motor Frame	1	Aluminium Die Casting
30	Oil Lifter	1	Plastic	65	Outer Cover	1	Steel Plate
31	Wearing Plate	1	Urethane Rubber	68	Handle	1	Plastic
32	Hose Coupling	1	Aluminium Die Casting	71	Shaft Sleeve	1	SUS304 (EN-X5CrNi18-10)
35	Oil Plug	1	SUS304 (EN-X5CrNi18-10)	76	Capacitor	1	
36	Lubricant		Turbine Oil (ISO VG32)	114	Relay Unit	1	SBR
50	Motor Bracket	1	Steel Plate				

Pump Performance Curve

LB-800A-51

Discharge Bore	50 mm
Total Head	max.15 m
Capacity	max. 0,31 m ³ /min
Motor Output	0,75 kW
Motor Input	1,13 kW
Phase	1
Voltage	230 V
Frequency	50 Hz
Rated Current	5,0 A
Starting Current	12,3 A
Poles	2
Revolution	S.S. 2730 r.p.m.
Starting Method	Capacitor
Insulation Class	E

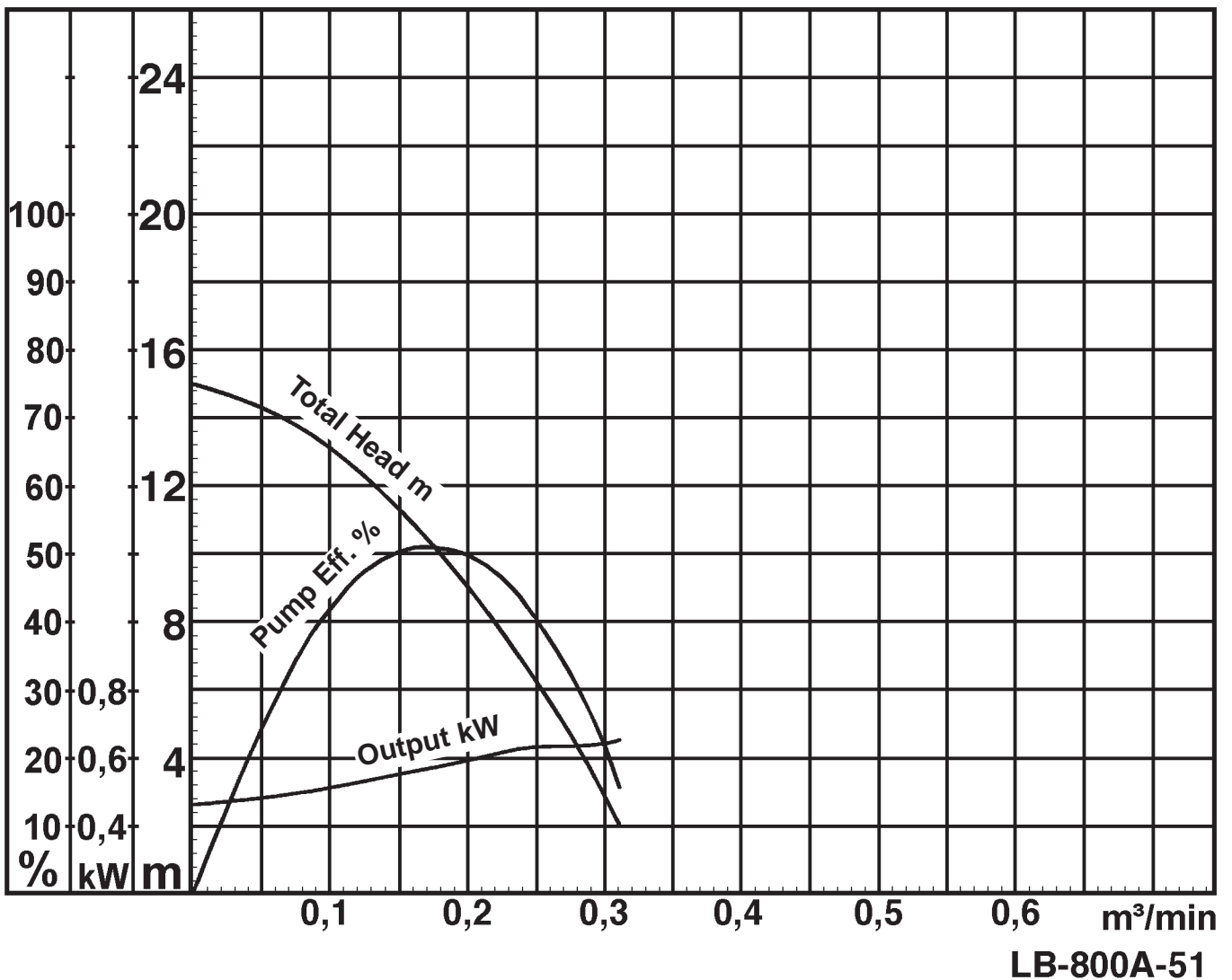

LB-800A-51